

# garry™

**ULTRA LIGHT  
PROFESSIONAL  
VACUUM**

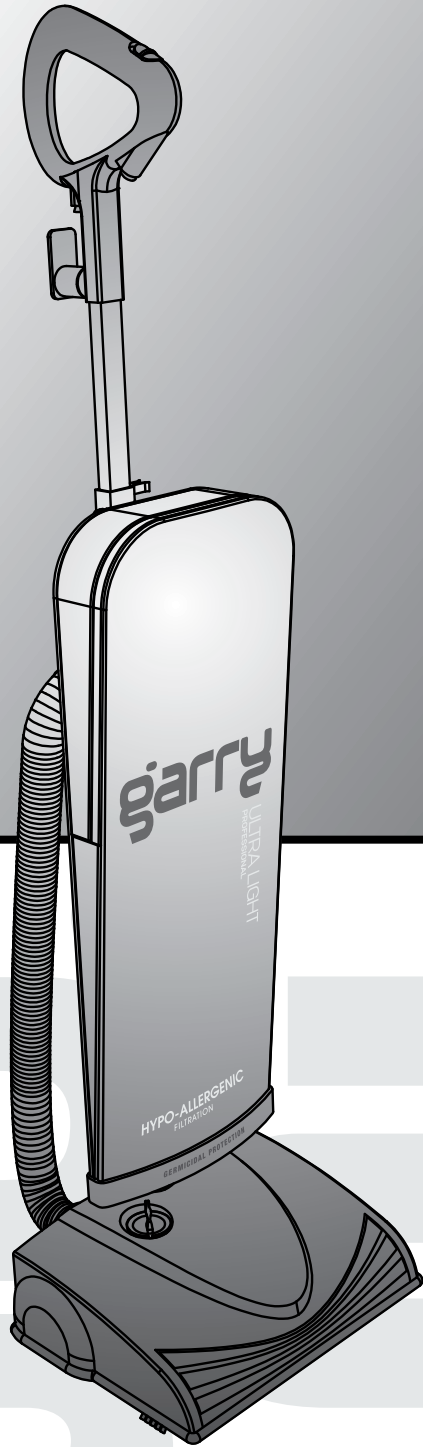

## Owner's Manual



By  
**ENVIONI™**

GV112108

# WELCOME!

Congratulations on your purchase of the Garry™ Ultra Light Professional Vacuum! With the Garry™ vacuum, you don't have to sacrifice the power of the heavier vacuums. This amazing product combines the convenience and ease of a light weight vacuum with the power you can count on. No more sore backs from vacuuming, no more ignoring the upstairs because you don't feel like lugging the heavy vacuum. The Garry™ Ultra Light Weight Vacuum will get your carpet or hard floors clean quickly and easily. And with a true hypo-allergenic filter bag, you can be sure that the dirt and dust you vacuum with stay out of the air. You'll soon agree that the Garry™ Ultra Light Professional Vacuum is one product you can't live without!



ENVIONI™

## TABLE OF CONTENTS

<b>IMPORTANT SAFETY INSTRUCTIONS</b>	<b>1</b>
<b>PRODUCT OVERVIEW</b>	<b>2</b>
<b>ASSEMBLY INSTRUCTIONS</b>	<b>3</b>
<b>INSTRUCTIONS FOR USE</b>	<b>5</b>
<b>CLEANING CARPETS AND FLOORS</b>	<b>5</b>
<b>USING ATTACHMENTS</b>	<b>5</b>
<b>MAINTENANCE</b>	<b>6</b>
<b>REPLACING THE FILTER BAG</b>	<b>6</b>
<b>CHANGING THE BELT</b>	<b>7</b>
<b>CLEANING THE ROLLER</b>	<b>7</b>
<b>IMPROVING AIRFLOW</b>	<b>8</b>
<b>SPARE PARTS</b>	<b>8</b>
<b>TROUBLESHOOTING</b>	<b>8</b>
<b>LIMITED WARRANTY</b>	<b>9</b>
<b>ARBITRATION AGREEMENT</b>	<b>10</b>

**PLEASE READ ALL SAFETY INSTRUCTIONS IN THIS PRODUCT MANUAL BEFORE USING THE GARRY VACUUM.**

**KEEP THIS PRODUCT MANUAL FOR FUTURE REFERENCE.**

## IMPORTANT SAFETY INSTRUCTIONS

Read all instructions before using your Garry™ vacuum.

**⚠ WARNING: To reduce the risk of fire, electric shock, or injury:**

- Do not leave your Garry™ vacuum cleaner plugged in. Always unplug from the outlet when not use and before servicing.
- To reduce the risk of electric shock, do not use your Garry™ vacuum cleaner outdoors or on wet surfaces
- Do not allow this or any appliance to be used as a toy. Pay close attention when using near children.
- Use the Garry™ vacuum only as described in this manual. Use only manufacturer recommended attachments.
- Do not use with a damaged cord or plug. If your Garry™ vacuum cleaner is not working as it should, discontinue use immediately and have it repaired at an authorized service center.
- Do not pull or carry by the cord, use the cord as a handle, close door on cord, or pull cord around sharp edges or corners. Do not run vacuum cleaner over cord. Keep cord away from heated surfaces.
- Do not unplug by pulling on cord. To unplug the unit, grasp the plug not the cord.
- Do not handle vacuum cleaner or plug with wet hands.
- Do not put any object into openings. Do not use with any opening blocked. Keep free of dust, lint, hair and anything that may reduce airflow.
- Keep hair, loose clothing, fingers and all parts of body away from openings and moving parts.
- Turn off the vacuum via the power switch before unplugging.
- Use extra care when cleaning on stairs.
- Do not use to pick up flammable or combustible liquid such as gasoline; Do not use in areas where these liquids may be present.
- Unplug the vacuum before connecting the hose.
- Do not pick up anything that is burning or smoking, such as cigarettes, matches, or hot ashes. Do not operate too close to space heaters or fireplaces
- Do not use without dust bag and/or filters in place.
- If airflow becomes blocked, switch off the vacuum immediately and unplug the cord before you remove the obstruction.
- Clear the floor of large, metal and sharp object such as coins, nuts and bolts, paper, foam and similar items prior to vacuuming.
- Always unplug the Garry™ vacuum cleaner before installing or removing accessories.
- This product operates at 120V AC, 60Hz only.
- For household use only.

## SAVE THESE INSTRUCTIONS

**THIS APPLIANCE HAS A POLARIZED PLUG.** To reduce the risk of electric shock, this vacuum cleaner has a polarized plug (one blade is wider than the other). This plug will fit in a polarized outlet only one way. If the plug does not easily fit in the outlet, reverse the plug. If it still does not fit, contact a qualified electrician to install the proper outlet. Do not change or modify the plug in any way.

## PRODUCT OVERVIEW

- |                               |                            |                             |
|-------------------------------|----------------------------|-----------------------------|
| <b>A.</b> Power Switch        | <b>G.</b> Hose             | <b>M.</b> Upholstery tool   |
| <b>B.</b> Handle              | <b>H.</b> Hose end         | <b>N.</b> Round nozzle tool |
| <b>C.</b> Power cord          | <b>I.</b> Hose divert knob | <b>O.</b> Middle tube       |
| <b>D.</b> Handle tube         | <b>J.</b> Light lens       | <b>P.</b> Hardware          |
| <b>E.</b> Outer bag           | <b>K.</b> Extension wand   | <b>Q.</b> Power Base        |
| <b>F.</b> Hypo-allergenic bag | <b>L.</b> Crevice tool     |                             |

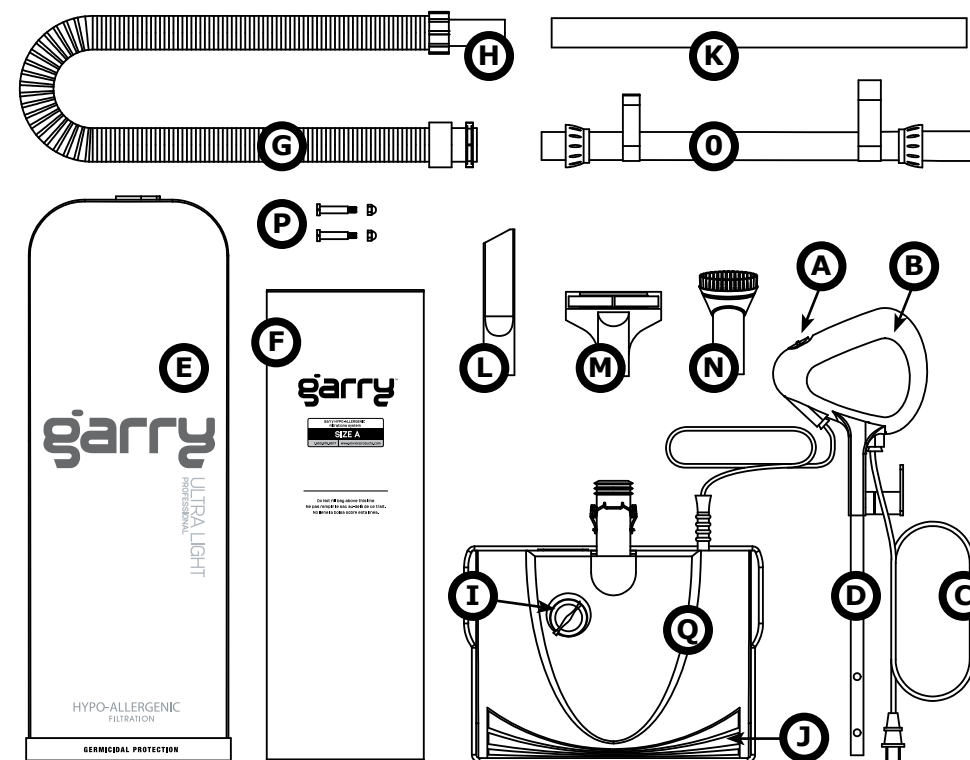

### Power base components:

- a.** Roller
- b.** Roller pulley
- c.** Motor drive shaft
- d.** Belt
- e.** Belt cover lid
- f.** Hose attachment socket
- g.** Intake opening
- h.** Bag spring clip
- i.** Side brush

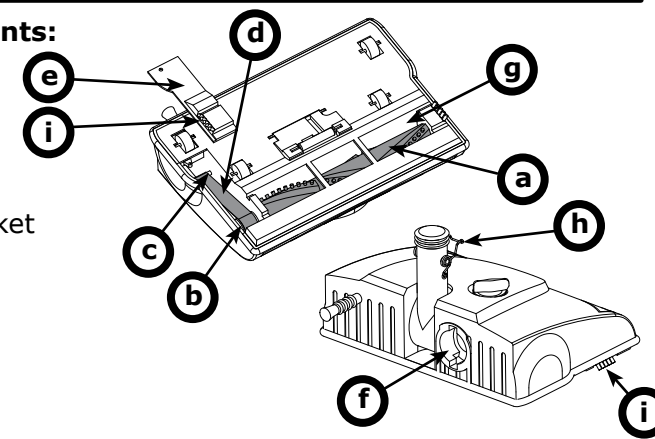

## ASSEMBLY INSTRUCTIONS

### Step 1

Insert handle tube into the tube on the bag as shown. Verify the handle tube's cord hook is facing away from the outer bag as shown in the image to the right. Use the hardware provided to secure the handle tube to the outer bag. Carefully tighten with a screwdriver. Do not overtighten.

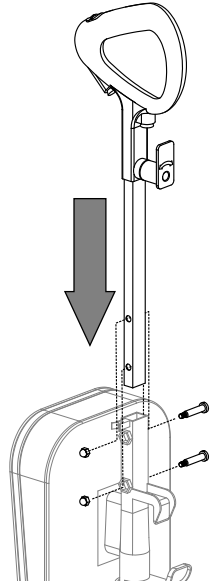

### Step 2

Clip the power cord into the upper clip near the handle. **See 4a.** Repeat this step by clipping the power cord to the bottom clip located on the bottom end of the handle close to the base. **See 4b.**

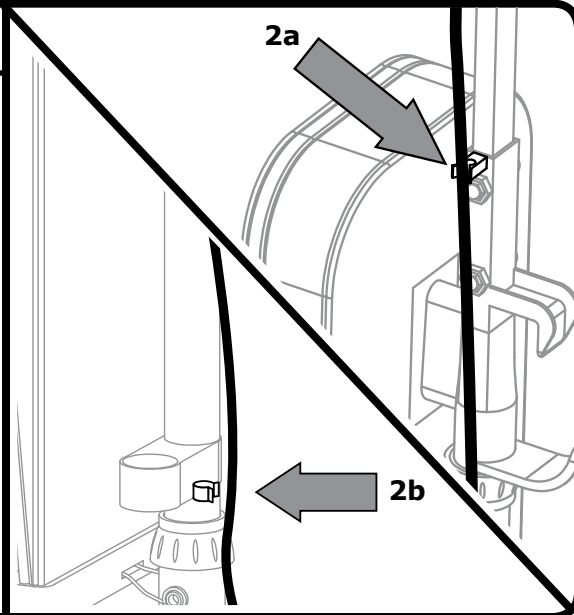

(Assembly Instructions continued)

### Step 3

Gently insert the hose into the hose attachment socket and twist clockwise until it softly clicks. Do not apply excessive force.

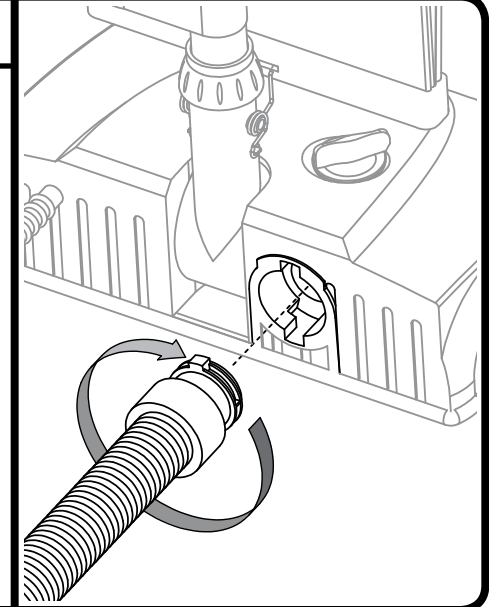

### Step 4

Raise the hose over the lowest hook on the handle and insert it into the hose retainer cup. Next, clip the hose into the hose clamp. This secures the hose while not in use.

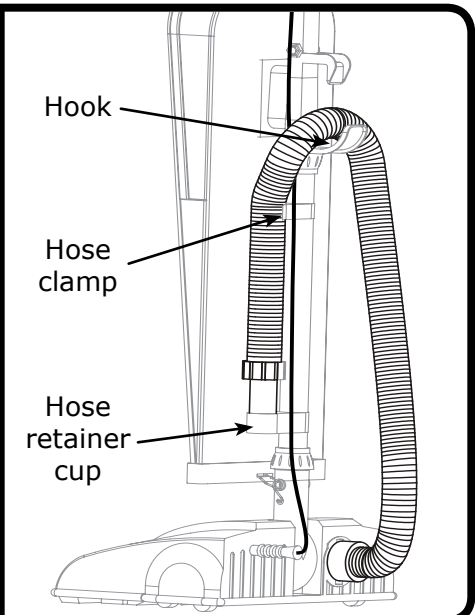

## INSTRUCTIONS FOR USE

### CLEANING CARPETS AND FLOORS

Unwind enough cord for the area you wish to clean with your Garry™ vacuum cleaner. **NOTE:** You can quickly remove the entire cord length by simply twisting the upper cable hook 1/2 turn and removing the entire cord. **See Figure 1.**

Plug the cord into an approved power outlet and turn on your Garry™ vacuum cleaner by moving the power switch on the handle to the forward position. You are now ready to clean your carpets and other flooring surfaces in your home.

**IMPORTANT:** Remember to always clear the floor of metal and large objects before you start to vacuum.

**NOTE:** If you hear a loud noise from your vacuum such as blockage by a large object or the roller freezes up, immediately turn off the vacuum and clear the roller and power base for any obstructions.

### USING ATTACHMENTS

To install your attachments, simply remove the hose end from the retainer cup and gently press on the desired attachment. **See Figure 2.**

**IMPORTANT NOTE:** You must turn the hose divert switch 90 degrees in the counter-clockwise direction in order to have suction come through the hose. **See Figure 3 .**

Use the **crevice tool** for cleaning in narrow or often difficult areas such as between couch cushions or along the baseboard where the wall meets the floor. Use the **upholstery tool** on your furniture and other sensitive fabrics to gently lift dust, pet hair and other debris. The **round nozzle tool** is perfect for cleaning very soiled spots like area rugs, and car mats.

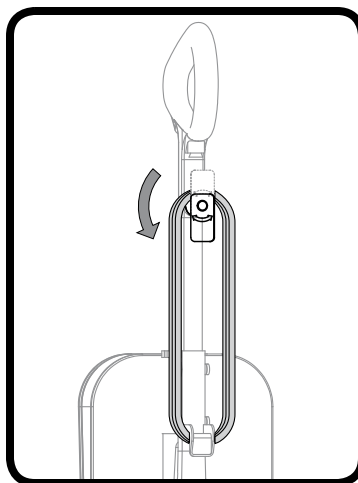

**Figure 1**

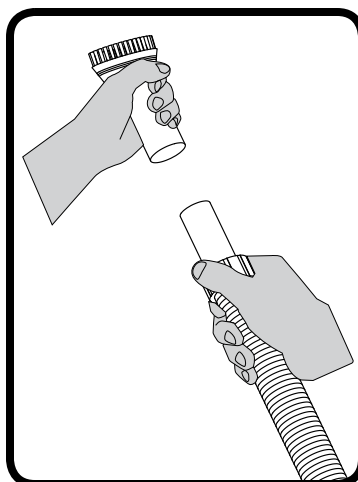

**Figure 2**

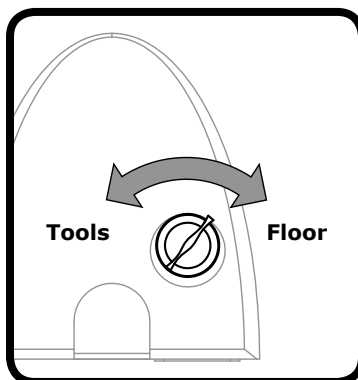

**Figure 3**

Also included with your Garry™ vacuum cleaner is an **extension wand**, which allows you to extend the reach of your vacuum to clean high areas and corners safely and thoroughly.

## MAINTENANCE

### REPLACING THE FILTER BAG

If you notice a loss of suction, the first thing you should do is check the bag. It is important to replace the bag whenever it becomes full. Do not try to reuse a bag. The Garry™ vacuum cleaner makes it so easy to check and replace the bag. You can easily check to see if the bag is full by gently pressing on the front of the outer bag with your hand.

When the bag needs replacing, follow these simple steps:

1. First, unzip the outer bag. Gently press on the bag release tab with one hand and carefully pull the bag away from the vacuum bag plate. **See Figure 4.**
2. As soon as you get the bag off of the plate, pull on the bag sealing tab to seal the bag before you remove it from the outer bag. **See Figure 5.**
3. Lift the bag up and out of the outer bag and dispose of it.
4. Before you install the new bag, quickly inspect the vacuum plate to make sure there are no blockages or other obstructions that might inhibit air flow.
5. Next, slide the new bag into the slots under the plate and pivot the bag up and around the vacuum plate. This should be a snug fit. Gently press the bag past the release tab until it clicks into place. **See Figure 6.**
6. Inspect the bag to make sure it is completely inside the outer back and zip the outer back all the way closed. You are now ready to continue using your Garry™ vacuum cleaner!

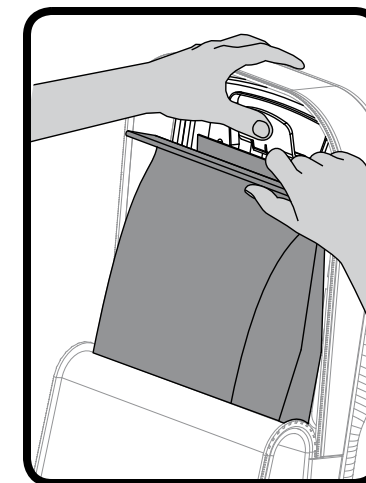

**Figure 4**

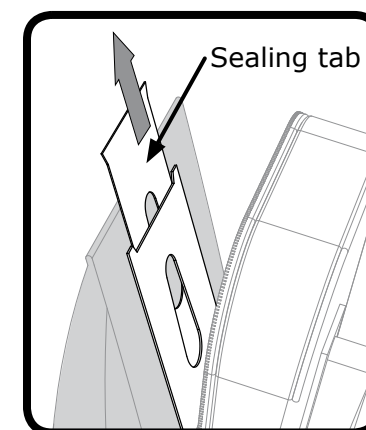

**Figure 5**

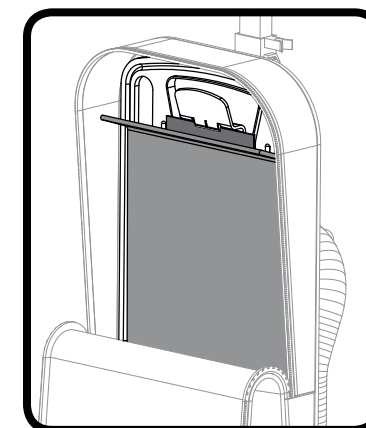

**Figure 6**

## CHANGING THE BELT

**⚠ WARNING:** Always unplug the cord from the outlet when servicing.

The belt should be replaced when necessary, usually once a year.

### Removing the belt:

1. Remove the screw which holds the belt cover lid to the unit and place it in a secure location.
2. Remove the old belt by rotating the roller pulley with one hand and pulling the belt off to the side with the other. Continue to rotate the pulley until the belt comes off.
3. Remove the belt from the motor drive shaft and discard.

### Installing the new belt:

1. Loop the new belt over the motor drive shaft.
2. Carefully stretch the belt toward the roller pulley and place the belt on the pulley and hold it with one hand. With the other hand, slowly rotate the roller pulley until the belt is successfully wrapped around the roller pulley.
3. Continue to rotate the roller 2 or 3 rotations while verifying that the belt is centered on the roller pulley.  
**See Figure 7.**
4. Replace the belt cover lid and fasten with screw.

## CLEANING THE ROLLER

After some time, string and other debris will start to accumulate on the roller. To keep the Garry™ vacuum running as efficient as possible, the debris should be removed. To do this, turn the vacuum over so the roller is viewable and accessible. With a sharp pair of scissors, carefully cut the debris from the roller by cutting parallel to the roller. Take care not to cut the bristles of the roller brush.

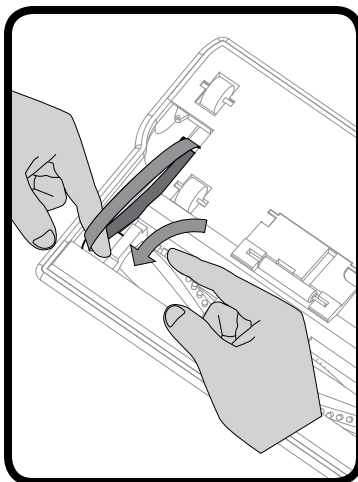

Figure 7

## IMPROVING AIRFLOW

If you notice your Garry™ vacuum has lost suction, is making unusual noise or is not inflating the bag as it should, follow these steps to improve airflow:

1. **Check the bag.** Replace the bag if it appears to be full. If a bag is very full it may have caused dust and dirt to collect in the system prior to the input funnel. If this is the case, please seek assistance from a qualified professional.
2. **Check the intake opening.** Clear any oversized objects that may have become lodged in the area.

## SPARE PARTS

Roller belt.....	GL501
Bag (Size A).....	GL502
Crevice tool.....	GL503
Upholstery tool.....	GL504
Round nozzle tool.....	GL505
Hose.....	GL506

## TROUBLESHOOTING

If you experience problems with your Garry™ vacuum cleaner, please review the following before contacting customer support. If you still require further assistance, please refer to the LIMITED WARRANTY near the end of this manual for Customer Support contact information.

### Problem: The vacuum cleaner won't turn on.

Try the following:

- Make sure the plug is firmly inserted into the outlet.
- Check the outlet's fuse or breaker. Replace or reset if necessary.

### Problem: Low cleaner suction.

Try the following:

- Replace bag if full.
- Remove obstructions from intake opening, hose, wand or attachments.
- Make sure the hose is connected properly.
- Make sure the hose divert switch is set to the proper setting according to the task at hand.

### Problem: Roller brush won't spin

Try the following:

- Check/replace belt if worn or broken.
- Remove obstructions around the roller.

### ARBITRATION AGREEMENT

### NOTES:

**THIS ARBITRATION AGREEMENT ("AGREEMENT") AFFECTS YOUR LEGAL RIGHTS AND REMEDIES BY PROVIDING THAT DISPUTES BETWEEN YOU AND THE SELLER OF THIS PRODUCT ("COMPANY"), MUST BE RESOLVED THROUGH BINDING ARBITRATION, RATHER THAN IN A COURT. PLEASE READ THIS AGREEMENT CAREFULLY. YOU ACCEPT THE TERMS OF THIS AGREEMENT BY RETAINING THE PRODUCT(S) SHIPPED IN CONNECTION WITH THIS AGREEMENT (THE "PRODUCT") FOR MORE THAN FOURTEEN (14) DAYS AFTER RECEIPT. IF YOU DO NOT AGREE TO THE TERMS OF THIS AGREEMENT, YOU MAY RETURN THE PRODUCT TO COMPANY WITHIN FOURTEEN (14) DAYS OF RECEIPT AT NO COST TO YOU.**

---

---

---

---

---

---

---

---

---

---

---

---

---

---

---

---

---

---

---

---

---

---

---

---

#### RESOLUTION OF CLAIMS OR DISPUTES.

Any claim or dispute between you and Company (or any of Company's subsidiaries or affiliates) arising out of or relating in any way to the Product or this Agreement shall be resolved through final, binding arbitration. This arbitration obligation applies regardless of whether the claim or dispute involves a tort, fraud, misrepresentation, product liability, negligence, violation of a statute, or any other legal theory. Both you and Company specifically acknowledge and agree that you waive your right to bring a lawsuit based on such claims or disputes and to have such lawsuit resolved by a judge or jury.

#### LIMITATION OF LEGAL REMEDIES.

All arbitrations under this Agreement shall be conducted on an individual (and not a class-wide) basis, and an arbitrator shall have no authority to award class-wide relief. You acknowledge and agree that this Agreement specifically prohibits you from commencing arbitration proceedings as a representative of others or joining in any arbitration proceedings brought by any other person.

#### ARBITRATION PROCEDURES.

- a. Before commencing any arbitration proceedings under this Agreement, you must first present the claim or dispute to Company by calling 818-217-2500 and asking for the Legal Department and allowing Company the opportunity to resolve the claim or dispute. If your claim or dispute is not resolved within sixty (60) days, you may commence arbitration proceedings in accordance with the terms of this Agreement.
- b. The arbitration of any claim or dispute under this Agreement shall be conducted pursuant to the American Arbitration Association's ("AAA") United States Commercial Dispute Resolution Procedures and Supplementary Procedures for Consumer-Related Disputes. These rules and procedures are available by calling the AAA or by visiting its web site at [www.adr.org](http://www.adr.org).
- c. The arbitration of any claim or dispute under this Agreement shall be conducted in the State of California or the location in which you received this Agreement.
- d. All administrative expenses of arbitration proceedings commenced under this Agreement shall be divided equally between you and Company, except that: (a) if the claim or dispute that is the subject of the arbitration proceedings is less than ten thousand dollars (US\$10,000), you will be responsible for no more than one hundred twenty-five dollars (US\$125) in administrative expenses; (b) if the claim or dispute that is the subject of the arbitration proceedings is more than ten thousand dollars (US\$10,000) but less than seventy-five thousand dollars (US\$75,000), you will be responsible for no more than three hundred seventy-five dollars (US\$375) in administrative expenses; and (c) if the claim or dispute that is the subject of the arbitration proceedings is more than seventy-five thousand dollars (US\$75,000), then you will be responsible for administrative expenses in accordance with the Commercial Fee Schedule provided by the AAA. You acknowledge and agree that each party shall pay the fees and costs of its own counsel, experts and witnesses

#### CHOICE OF LAW.

This Agreement shall be governed by the United States Federal Arbitration Act and the laws of the state of California.

#### SEVERABILITY.

If any provision of this Agreement is declared or found to be unlawful, unenforceable or void, such provision will be ineffective only to the extent that it is found unlawful, unenforceable or void, and the remainder of the provision and all other provisions shall remain fully enforceable.

